

SLE

Building wash

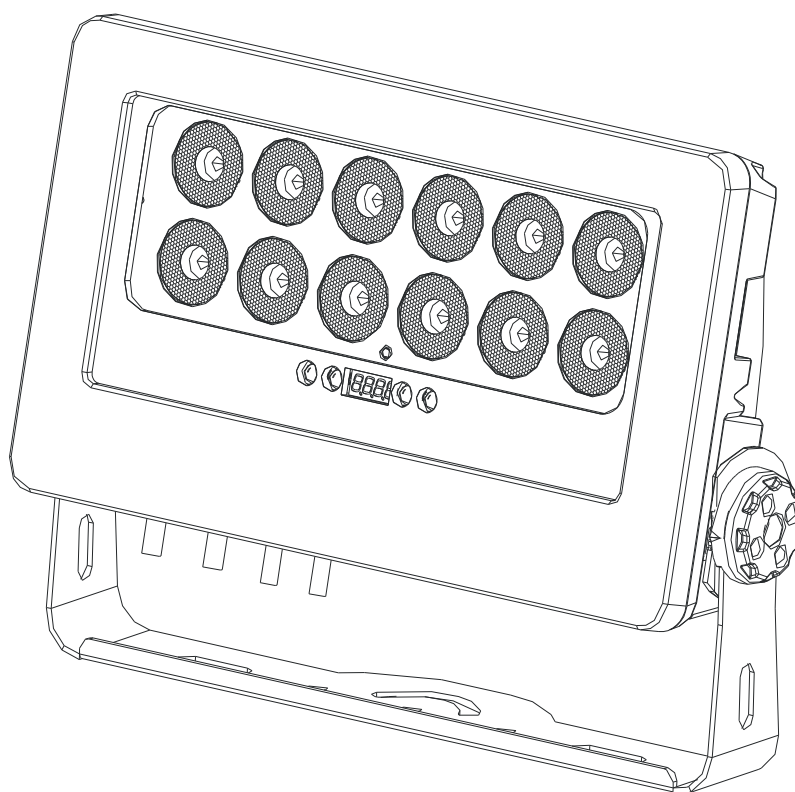

AEDI WASH UNO 48 MC

User Manual

Please read the instructions carefully before use

Version 1.0

CONTENTS

1. SAFETY INSTRUCTION	2
2. ABOUT THE PRODUCT	4
3. TECHNICAL SPECIFICATIONS	4
4. ACCESSORIES	5
5. HOW TO SET THE FIXTURE	6
5.1 CONTROL PANEL	6
5.2 MAIN FUNCTIONS.....	7
6. HOW TO CONTROL THE UNIT.....	13
6.1 DMX controller	13
6.2 DMX 512 configuration.....	13
7. DMX512 CONNECTIONS.....	16
8. TROUBLESHOOTING.....	17
9. FIXTURE CLEANING AND MAINTANCE	18

1. SAFETY INSTRUCTION



WARNING

Please read the instructions carefully which includes important information about the installation, operation and maintenance.

- Please keep this User Guide for future consultation. If you sell the unit to another user, be sure that they also receive this instruction booklet.



DANGER!
Safety hazard.
Risk of severe injury or death.

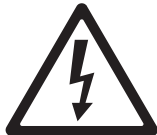

DANGER!
Hazardous voltage. Risk of lethal or severe electric shock.



WARNING!
Fire hazard.



WARNING!
LED light emission. Risk of eye injury.



WARNING!
Burn hazard. Hot surface. Do not touch.



WARNING! Refer to user manual.

Caution:

- All fixtures are intact from the manufacturer, please operate follow up the user manual, artificial fault are not under guarantee repair.
- Unpack and check carefully that there is no transportation damage before using the unit per first time.
- DO install and operate by operator.
- Use safety chain when fixes the unit.
- The unit must be installed in a location with adequate ventilation, at least 50 cm from adjacent surfaces.
- Before operating, ensure that the voltage and frequency of power supply match the power requirements of the unit.
- It's important to ground the yellow/green conductor to earth in order to avoid electric shock.
- Maximum ambient temperature T_a : 40°C. DO NOT operate it where the temperature is higher than this.
- DO NOT connect the device to any dimmer pack.
- Make sure there are no flammable materials close to the unit while operating, as it is fire hazard.
- Look over power wires carefully, replace immediately if there is any damage.
- Unit surface temperature may reach up to 60°C. DO NOT touch the housing bare-hand during its operation.
- Avoid any inflammable liquids, water or metal objects entering the unit. Once it happens, cut

off the mains power immediately.

- DO NOT operate in dirty and dusty environment, also cleaning fixtures regularly.
- DO NOT allow children to operate the fixture.
- DO NOT touch any wire during operation as there might be a hazard of electric shock.
- Avoid power wires together around other cables.
- Replace fuse only with the same type.
- In the event of serious operating problem, stop using the unit immediately.
- The housing and the lenses must be replaced if they are visibly damaged.
- DO NOT open the unit as there are no user serviceable parts inside. Never try to repair the unit by yourself. Repairs carried out by unskilled people can lead to damage or malfunction. Please contact the nearest authorized technical assistance center.
- Disconnect the mains power if the fixture is not used for a long time.
- DO use original packing materials once transport it again.
- To prevent or reduce the risk of electrical shock or fire, do not expose the unit to rain or moisture.
- DO NOT look directly at the LED light beam while the fixture is on.

If you use a 230V 50Hz power supply, DO NOT connect in series more than 20 units; use another main supply for the next 20 fixtures.

If you use a 120V 60Hz power supply, DO NOT connect in series more than 10 units; use another main supply for the next 10 fixtures.

The manufacturer does not take responsibility if the device is operated under conditions other than described in this manual. The product may suffer damage and the guarantee becomes void.

Installation:

The unit should be mounted via its screw holes on the bracket. Always ensure that the unit is firmly fixed to avoid vibration and slipping while operating. Always ensure that the structure to which you are attaching the unit is secure and is able to support a weight of 10 times of the unit's weight. Also always use a safety cable that can hold 12 times of the weight of the unit when installing the fixture in the air.

The equipment must be fixed by professionals. And it must be fixed at a place where is out of the touch of people and has no one pass by or under it.

2. ABOUT THE PRODUCT

The stylishly modern and unassuming exterior of AEDI WASH GLOBUS houses state-of-the-art RGBW LED technology and made using the highest quality materials and construction methods. Bringing the flexibility to outdoor application, this powerful lighting fixture is ideally suited to use in landscape and building illumination, and IP66 ensures safe operation in even the most demanding areas. With integral built-in AC/DC power supply of 230V AC.



3. TECHNICAL SPECIFICATIONS

- An ideal replacement for the outdoor metal halide fixtures. Wash Uno 48 MC produces powerful and consistent light output, makes its efficiency and cost-effective.
- Compact design with active cooling system in rugged die-cast aluminum housing to ensure reliable performance under harsh environment.
- It includes 16 pre-programmed movement patterns for all working modes - 4/5/7 DMX channels.
- Easy installation with swivel tilt mechanism for quick positioning.
- Different optical systems, ideal for multiple applications – for the illumination of buildings, bridges, stadiums, landscapes, theme parks, and more

- **Mounting:** Manual Tilt Adjustable Bracket
- **Optical systems:** 10° / 16° / 30°
- **Light Source:** 12×10 Multichip RGBW CREE LEDs
- **LED color variants:** red / green / blue / neutral white (4000° K)
- **Lumen Output:** > 2950 lm
- **Input Voltage:** 100-240V AC 50/60Hz Daisy Chain System
- **Wiring:** Dimmable Electronic Control Gear USITT DMX 512 A
- **Power Consumption:** Max. 112 W / Average consumption in color mixing mode 60 W
- **Power cable connection:** IP rated connectors
- **Service lifetime:** 50,000 hrs / L70 /@ 25°C
- **Operating ambient tem:** -20°C/+40°C
- **Materials:** Housing: die-cast aluminum.
Cover: clear hardened glass.
- **IP Rating:** IP66
- **Dimension:** 454× 116×330mm
- **Weight:** 11.2 kg
- **Finishing:** White aluminum. (RAL 9006).
- **Accessories:** DMX controllers: AEDITEMPA ATTACA & AEDITEMPA LIBA

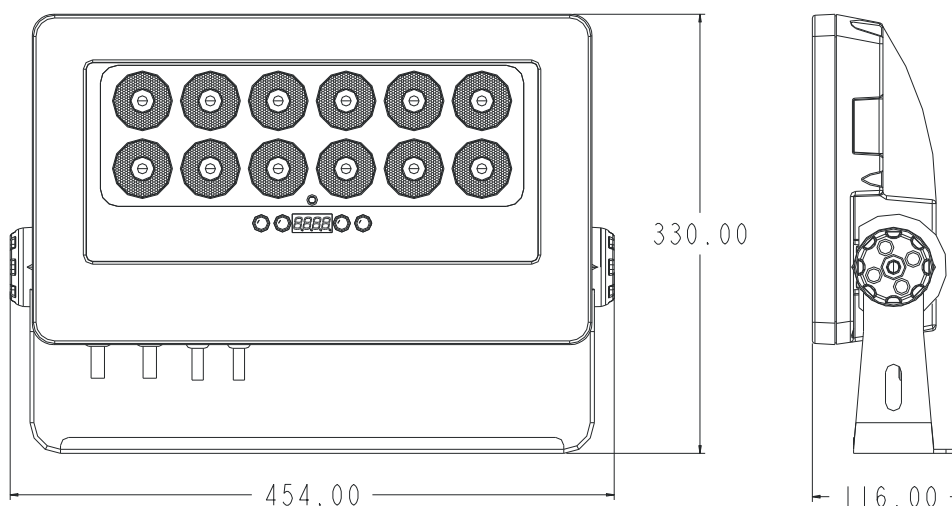

4. ACCESSORIES

- Power Extension Cable 1, 2, 5, 10 m.
- DMX Extension Cable 1, 2, 5, 10 m.

5. HOW TO SET THE FIXTURE

5.1 CONTROL PANEL

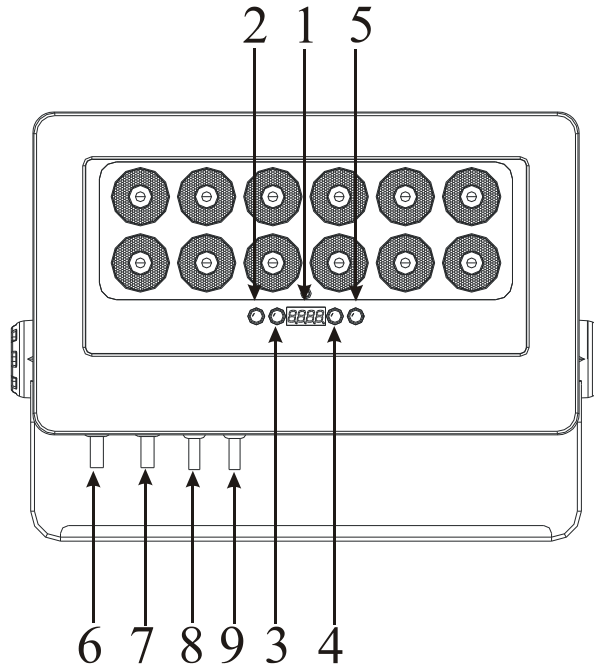

1. Display:

To show the various menus and the selected functions

Button:

2. MENU	To select the programming functions
3. DOWN	To confirm the selected functions
4. UP	To go forward in the selected functions
5. ENTER	To confirm the selected functions

6. POWER IN:

Water proof connectors for power input

7. POWER OUT:

Water proof connectors for power output

8. DMX IN:

Water proof connectors for DMX 512, use 3-pin XLR cable to link the unit together.

9. DMX OUT:

Water proof connectors for DMX 512 operation with 3-pin XLR cable to link the next unit.

5.2 MAIN FUNCTIONS

To select any functions, press the **MENU** button until the required one is shown on the display.

Select the function by the **ENTER** button and the display will blink. Use the **DOWN** and **UP**

button to change the mode. Once the required mode has been selected, press the **ENTER** button to setup or it will automatically return to the main functions without any change after idling one

minute. Back to the functions without any change press the **MENU** button. The main functions are shown below:

Once you set **Loc** to **GPS**, after running in show mode for 5 minutes without any change or restarting the unit, the key board become locked. Press the **ENTER** button to enable the menu, the display will show **---**, press the **UP** and **DOWN** button until it shows **---**, then press the **ENTER** to unlock.

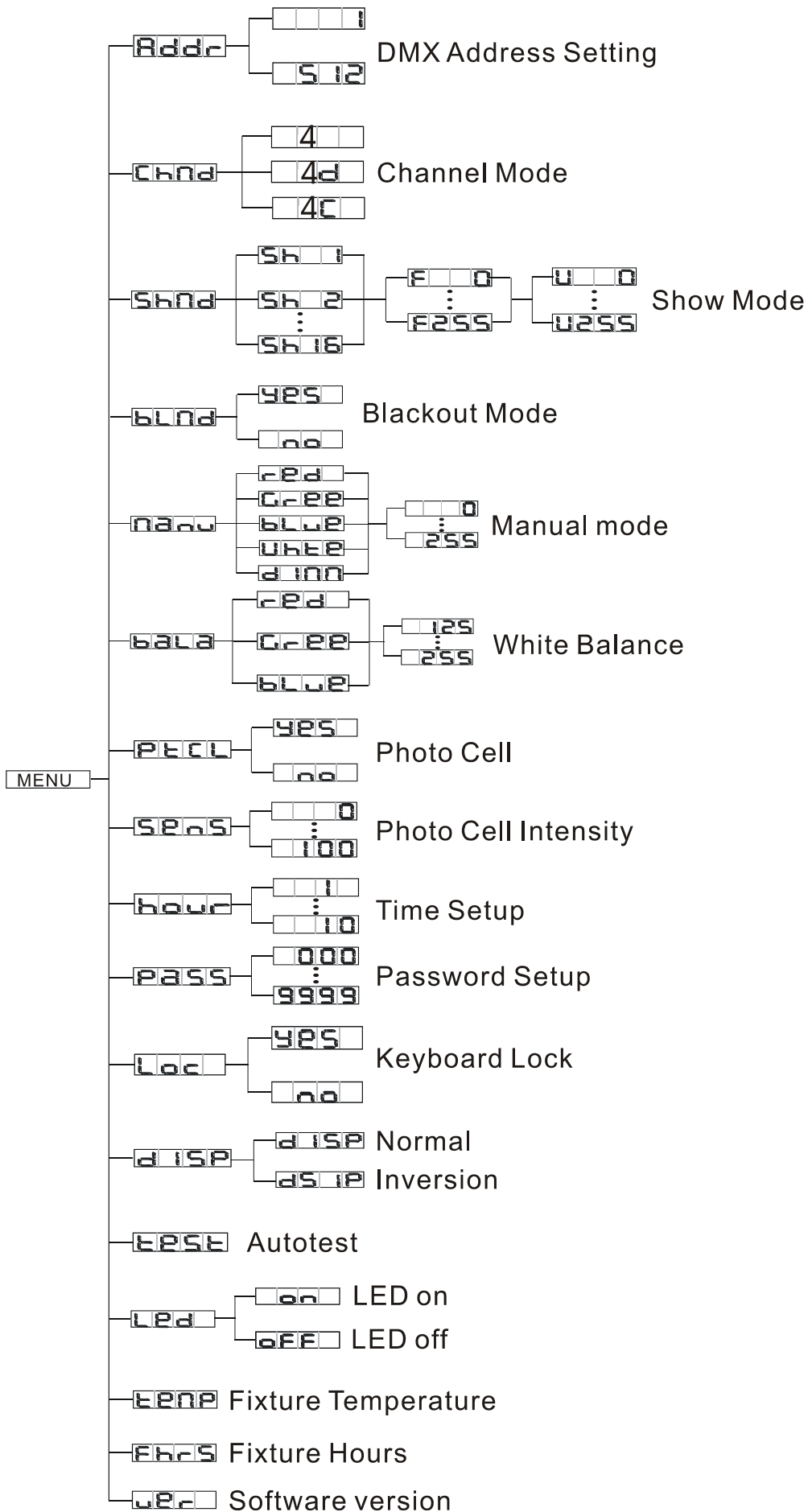

Addr DMX 512 Address Setting

Select the **Addr**, press the **ENTER** button and the display will blink. Use the **DOWN** and **UP** button to adjust the DMX512 address between **0000** and **512**. Once the address has been selected, press the **ENTER** button to setup or automatically exit menu mode without any change after one minute. Back to the previous functions without any change press the **MENU** button.

Chnd Channel mode

Select the **Chnd**, press the **ENTER** button and the display will blink. Use the **DOWN** and **UP** button to select the **4** (4 Channels: Red, Green, Blue, White), **4d** (5 Channels: Red, Green, Blue, White, Dimmer) or **4C** (7 Channels: Red, Green, Blue, White, Color, Dimmer, Strobe) Mode. Once selected, press the **ENTER** button to store or automatically exit menu mode without any change after one minute. To go back to the functions without any change press the **MENU** button.

Shnd Show mode

Select the **Shnd**, press the **ENTER** button and the display will blink. Use the **DOWN** and **UP** button to select the **SH 1** (Show 1) or **SH 2** (Show 2)...**SH 16** (Show 16) Mode. Once selected, press the **ENTER** button to setup. Press the **ENTER** button, **F 00** will blink on the display, use **DOWN** and **UP** button adjust the fade time (0~255); press the **ENTER** button to store and **U 00** will blink on the display, use the **DOWN** and **UP** button adjust the wait time (0~255), press the **ENTER** button to store or automatically return to the main functions without any change after one minute. To go back to the previous functions without any change press the **MENU** button.

blnd Blackout mode

Select the **blnd**, press the **ENTER** button and the display will blink. Use the **DOWN** and **UP** button to select the **SES** (blackout) or **aa** (normal). Once selected, press the

ENTER button to setup or automatically exit menu mode without any change after one minute. To go back to the functions without any change press the **MENU** button.

MANU Manual Mode

Select the **MANU**, press the **ENTER** button and the display will blink. Use the **DOWN** and **UP** button to select the **RED** (Red), **GREEN** (Green), **BLUE** (Blue), **WHITE** (White) or **DIMM** (Dimmer). Once selected, press the **ENTER** button to confirm, and use the **DOWN** and **UP** button to adjust the value between **0000** and **255**, then press the **ENTER** button to store, or automatically exit menu mode without any change after one minute. To go back to the functions without any change press the **MENU** button.

BALB White Balance

Select the **BALB**, press the **ENTER** button and the display will blink. Use the **DOWN** and **UP** button to select the **RED** (Red), **GREEN** (Green), **BLUE** (Blue). Once selected, press the **ENTER** button to confirm, and use the **DOWN** and **UP** button to adjust the value between **125** and **255**, then press the **ENTER** button to store, or automatically return to the main functions without any change after one minute. To go back to the previous functions without any change press the **MENU** button.

PECL Photo Cell

Select the **PECL**, press the **ENTER** button and the display will blink. Use the **DOWN** and **UP** button to select the **YES** (Be controlled by sunlight) or **NO** (Not be controlled by sunlight). Once select, press the **ENTER** button to setup or automatically return to the main functions without any change after one minute. Back to the previous functions press the **MENU** button.

SENS Photo Cell Intensity

Select the **SENS**, press the **ENTER** button and the display will blink. Use the **DOWN** and

UP button to adjust the intensity value between and . Once selected, press the **ENTER** button to setup or automatically return to the main functions without any change after one minute. Back to the previous functions press the **MENU** button.

Time Setup

Press the **MENU** button to show on the display. Press the **ENTER** button and the display will blink. Use the **DOWN** and **UP** button to select the (1 hour) ... (10 hours) mode. Once select, press the **ENTER** button to setup or automatically return to the main functions without any change after one minute. Back to the previous functions press the **MENU** button.

Password Setup

Press the **MENU** button to show on the display. Press the **ENTER** button and the display will blink. Use the **DOWN** and **UP** button to change the password from the Once select, press the **ENTER** button to setup or automatically return to the main functions without any change after one minute. Back to the previous functions press the **MENU** button.

Key Board Lock

Press the **MENU** button up to when the is showing on the display. Press the **ENTER** button and the display will blink. Use the **DOWN** and **UP** button to select the (lock the key board) or (normal), Once select, press the **ENTER** button to setup or automatically return to the main functions without any change after one minute. Back to the previous functions press the **MENU** button.

DISP Display Inversion

Press the **MENU** button up to when the **DISP** is showing on the display. Press the **ENTER** button and the display will blink. Use the **DOWN** and **UP** button to select the **DISP** (normal) or **ASIP** (inverse), Once the mode has been selected, press the **ENTER** button to setup or automatically return to the main functions without any change after one minute. To go back to the previous functions without any change press the **MENU** button.

TEST Auto Test

Press the **MENU** button up to when the **TEST** is blinking on the display. Press the **ENTER** button and the unit will run self-test by built-in program. To go back to the functions press the **MENU** button again.

LED LED Display

Press the **MENU** button up to when the **LED** is shown on the display. Press the **ENTER** button and the display will blink. Use **DOWN** and **UP** button to select the **ON** (display is always on) or **OFF** (display off 20 seconds after exit menu) mode. Once select, press the **ENTER** button to setup or exit menu mode without any change after one minute. Back to the functions without any change press **MENU** button again.

TEMP Temperature Test

Press the **MENU** button up to when the **TEMP** is blinking on the display. Press the **ENTER** button and the display will show the temperature of the unit. To go back to the functions press the **MENU** button again.

FHRS Fixture Hours

Press the **MENU** button up to when the **FHRS** is blinking on the display. Press the **ENTER** button and the display will show the number of working hours of the unit. To go back to the functions press the **MENU** button.



Software version

Press the **MENU** button up to when the is blinking on the display. Press the **ENTER** button and the display will show the version of software of the unit. To go back to the functions press the **MENU** button again.

6. HOW TO CONTROL THE UNIT

You can operate the unit in two ways:

1. By master/slave built-in preprogram function.
2. By DMX controller.

No need to turn the unit off when you change the DMX address, as new DMX address setting will be affected at once.

6.1 MASTER/SLAVE BUILT IN PREPROGRAMMED FUNCTION

By linking the units in master/slave connection, the first unit will control the other units to give an automatic, sound activated, synchronized light show. This function is good when you want an instant show. In Master/Slave mode, the first fixture whose DMX input jack has with nothing connect will be master automatically, set other units to slave mode.

6.2 DMX Controller

Use universal DMX controller to control the units, you have to set DMX address from 1 to 512 channel so that the units can receive DMX signal.

Press the **MENU** button up to when the is showing on the display. Pressing **ENTER** button and the display will blink. Use **DOWN** and **UP** button to change the DMX512 address. Once the address has been selected, press and keep **ENTER** button pressed up to when the display stops blinking or storing automatically 8 seconds later. To go back to the functions without any change press the **MENU** button again.

Please refer to the following diagram to address your DMX512 channel for the first 4 units:

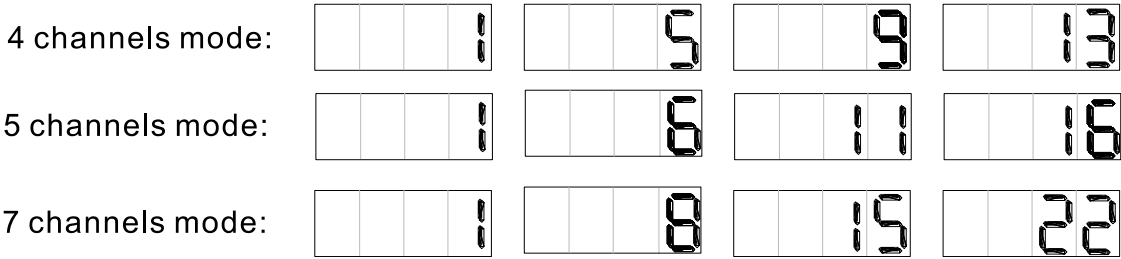

6.3 DMX 512 Configuration

4/5/7 Channels Mode:

DMX512 Configurations								
4 Channels(4 Mode)				5 Channels (4D Mode)				
Ch1	Ch2	Ch3	Ch4	Ch1	Ch2	Ch3	Ch4	Ch5
RED	GREEN	BLUE	WHITE	RED	GREEN	BLUE	WHITE	DIMMER
7 Channels (4C Mode)								
Ch1	Ch2	Ch3	Ch4	Ch5	Ch6	Ch7		
RED	GREEN	BLUE	WHITE	COLOR	DIMMER	STROBE		
				248-255 Preset color32 240-247 Preset color31 232-239 Preset color30 224-231 Preset color29 217-223 Preset color28 209-216 Preset color27 201-208 Preset color26 194-200 Preset color25 186-193 Preset color24 178-185 Preset color23 170-177 Preset color22 163-169 Preset color21 155-162 Preset color20 147-154 Preset color19 140-146 Preset color18 132-139 Preset color17 124-131 Preset color16 116-123 Preset color15 109-115 Preset color14 101-108 Preset color13 093-100 Preset color12 085-092 Preset color11 078-084 Preset color10 070-077 Preset color9 062-069 Preset color8 055-061 Preset color7 047-054 Preset color6 039-046 Preset color5 031-038 Preset color4 024-030 Preset color3 016-023 Preset color2 008-015 Preset color1 001-007 OFF		248-255 OPEN 240-247 RANDOM STROBE 232-239 OPEN 190-231 SLOW CLOSE FAST OPEN 182-189 OPEN 140-181 SLOW OPEN FAST CLOSE 132-139 OPEN 16-131 8-15 OPEN 0-7 OFF		

7. DMX512 CONNECTIONS

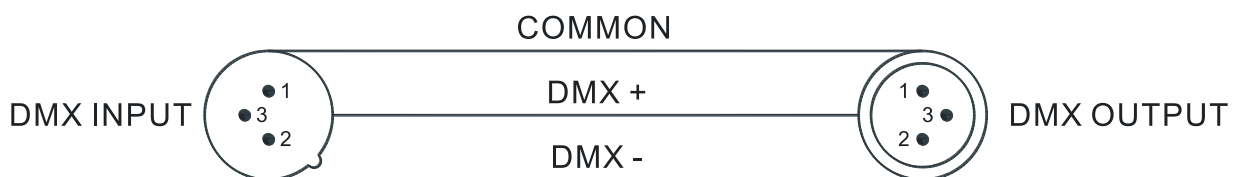
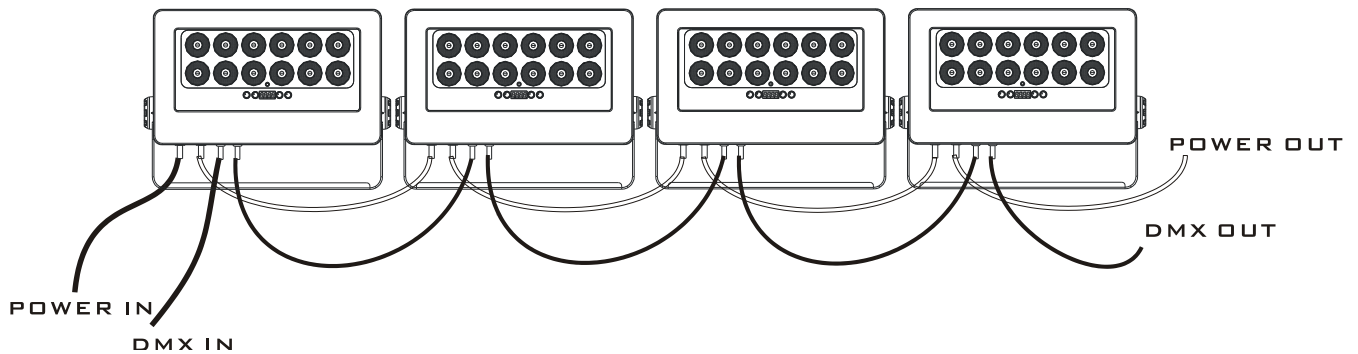

Termination reduces signal errors and to avoid signal transmission problems and interference. It is always advisable to connect a DMX terminal.

(Resistance 120 ohm 1/4W) between pin2(DMX-) and pin3(DMX+) of the last fixture.



1. If you use a controller with 5 pins DMX output, you need to use a 5 to 3 pin adapter-cable.
2. At last unit, the DMX cable has to be terminated with a terminator. Solder a 120 ohm 1/4W resistor between pin 2(DMX-) and pin 3(DMX+) into a 3-pin XLR-plug and plug it in the DMX-output of the last unit.
3. Connect the unit together in a `daisy chain` by XLR plug from the output of the unit to the input of the next unit. The cable can not branched or split to a `Y` cable. DMX 512 is a very high-speed signal. Inadequate or damaged cables, soldered joints or corroded connectors can easily distort the signal and shut down the system.
4. The DMX output and input connectors are pass-through to maintain the DMX circuit, when one of the units' power is disconnected.
5. Each lighting unit needs to have an address set to receive the data sent by the controller. The address number is between 0-511 (usually 0 & 1 are equal to 1).
6. The end of the DMX 512 system should be terminated to reduce signal errors.
7. 3 pin XLR connectors are more popular than 5 pin XLR.

3 pin XLR: Pin 1: GND, Pin 2: Negative signal (-), Pin 3: Positive signal (+)

5 pin XLR: Pin 1: GND, Pin 2: Negative signal (-), Pin 3: Positive signal (+), Pin 4/Pin 5: Not used.

8. TROUBLESHOOTING

Following are a few common problems that may occur during operation. Here are some suggestions for easy troubleshooting:

Problem	Possible Cause	Action
The unit does not work, no light.	Incorrect power cable connection.	Check the connection of power.
	Incorrect mains voltage.	Measure the mains voltage on the main connector.
The unit does not respond properly to the DMX control.	Incorrect DMX cable connection.	Check DMX connectors and cables to see if link properly. Repair or replace damaged wires.
	Incorrect address assignment to the units.	Check the addresses of the units and the protocol settings.
	Unfinished data connection.	Insert a terminal plug in the output jack of the last unit of the connection.
	It has been set up an operating mode different from the DMX mode used.	Check the operating mode set up.
		Try to use another DMX controller.

9. FIXTURE CLEANING AND MAINTANCE

The cleaning of internal must be carried out periodically to optimize light output. Cleaning frequency depends on the environment in which the fixture operates: damp, smoky or particularly dirty surrounding can cause greater accumulation of dirt on the fixture's optics.

- Clean with soft cloth using normal glass cleaning fluid.
- Always dry the parts carefully.
- Clean the external optics at least every 20 days. Clean the internal optics at least every 30/60 days.

Declaration of Conformity

We declare that our products (lighting equipments) comply with the following specification and bears CE mark in accordance with the provision of the Electromagnetic Compatibility (EMC) Directive 89/336/EEC.

EN55103-1: 2009 ; EN55103-2: 2009; EN62471: 2008;
EN61000-3-2: 2006 + A1:2009 + A2:2009; EN61000-3-3: 2008.

&

Harmonized Standard

EN 60598-1:2008 + All:2009; EN 60598-2-17:1989 + A2:1991;
EN 62471:2008; EN 62493: 2010
Safety of household and similar electrical appliances
Part 1: General requirements



WWW.SLEPROJECTS.COM

© 2014. All specifications subject to change without notice